

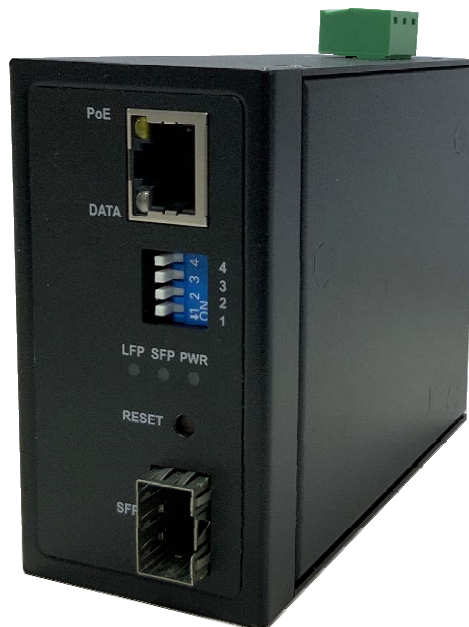

Industrial Fiber Gigabit Media Converter
10/100/1000Base-T to
100/1000Base-FX
With IEEE802.3bt/at/af PoE Injector

DF100GB



Product Descriptions

DF100GB is an industrial grade 100/1000Base-FX to 10/100/1000Base-T GbE media converter/Injector, which allows one Ethernet UTP RJ-45 port to be inter-changeably connected to one Fiber SFP port. In addition, the RJ-45 port is compliant with IEEE802.3bt/at/af standards to provide up to 90Watt Power over Ethernet (PoE). This PoE media converter combines the SFP fiber data with a 52~57VDC power input, and injects up to 90Watt to the IEEE802.3bt/at/af powered device (PD) over the existing CAT5 UTP cable.

The DF100GB converter includes a PD signature sensing and power monitoring features. The PoE features over-current protection (OCP), over-voltage protection (OVP), and over-temperature protection (OTP). With the Link Fault Pass-through (LFP) function, the DF100GB can monitor both the fiber and copper RX ports for loss of signal. In case of a loss of RX signal on one media port, the converter will automatically disable the TX signal to the other media port, thus passing through the link fault. It then sends out the far end fault (FEF) signal to stop sending link pulse to the link partner once a loss of the fiber RX signal is encountered. Then the link partner will synchronously stop sending data. FEF prevents loss of valuable data transmitted over invalid link. Combining the LFP and FEF troubleshooting features of DF100GB, both end devices can be notified of a loss of fiber link.

Key Features

- IEEE802.3bt/at/af PoE (Power over Ethernet) Injector PSE compatible
 - Power input: 52-57VDC
 - Max. 90Watt PoE output
 - OCP, OVP, & OTP protections
 - Legacy PD Compatible
 - Minimum load sensing
 - Fault Protection Input
- LFP (Link Fault Pass-through) and FEF (Far End Fault)
- Media Converter with one 10/100/1000Base-T Gigabit Ethernet UTP RJ45 port and one 100/1000Base-FX Gigabit Ethernet Fiber SFP port
- Supports 10/100/1000Base-T auto negotiation on the UTP port
- Supports 802.3x flow control for full-duplex ports and backpressure for half-duplex ports
- Supports jumbo frame (Normal Mode: 2KB, Cut-Through Mode: 9KB)
- Supports SFP multi-mode/single-mode fiber plugs with different distances.
- DIP switch settings

- DIP 1: OFF for Normal operation
- DIP 2: To select SFP for 100Base-FX or 1000base-FX
- DIP 3: To enable LFP function
- DIP 4: OFF for Normal operation
- RESET push button to activate DIP Switch settings
- RoHS Compliance

Technical Specifications

- Standards
 - IEEE802.3 10Base-T
 - IEEE802.3u 100ase-TX
 - IEEE802.3ab 1000Base-T
 - IEEE802.3z 100Base-FX/1000Base-X
 - IEEE802.3x full-duplex flow control
 - Cable
 - UTP : Cat. 5e cable up to 100m
 - Fiber :
 - multi-mode for 1-2km
 - single-mode for 10-50km
- Power
 - Input : 52~57VDC
 - PoE output: up to 90Watts
- Ambient Temperature : -40 ~ +70°C
- Humidity : 5~90%
- Dimensions : 39 (H) x 85 (W) x 92 (D) mm
- Certification : FCC Part 15 Class A, CE Mark

Network Interfaces

Category	Connector	Transmission	Max. Cable/Fiber Length
10/100Base-TX	RJ-45	Full/Half Duplex	100M
1000Base-T	RJ-45	Full Duplex	100M
100Base-FX	SFP	Full Duplex	Multi-Mode 2km Single-Mode 50km
1000Base-X	SFP	Full Duplex	Multi-Mode 2km Single-Mode 50km

DIP Switches

Dip Switch #	Function	On / Off	Descriptions
1		OFF	For Normal Operation
2	SFP	OFF	Select 100Mbps for SFP Connection
		ON	Select 1000Mbps for SFP Connection
3	LFP	OFF	Disable LFP & FEF Function
		ON	Enable LFP & FEF Function
4		OFF	For Normal Operation

LED Indicators:

LED	Color /Action	Descriptions
PWR	Green ON	DC power is ON
SFP	Green ON	SFP Link at 1000Mbps
	Green Blink	SFP fiber data is present
	Amber ON	SFP Link at 100Mbps
	Amber Blink	SFP fiber data is present
LFP	Amber ON	LFP/FEF Link Loss event occurred (If DS#3 is set ON).
DATA	Green ON	UTP link at 1000Mbps
	Green Blink	UTP data is present
	Amber ON	UTP link at 10/100Mbps
	Amber ON	UTP data is present
PoE	Amber ON	PoE is powering at IEEE802.3bt (*).

***Note:** When PoE is ON at IEEE802.3at/af, LED PoE will not lit, but the LED DATA will lit indicating the PD is powered ON by PoE IEEE802.3at/af.

Application Scenario:

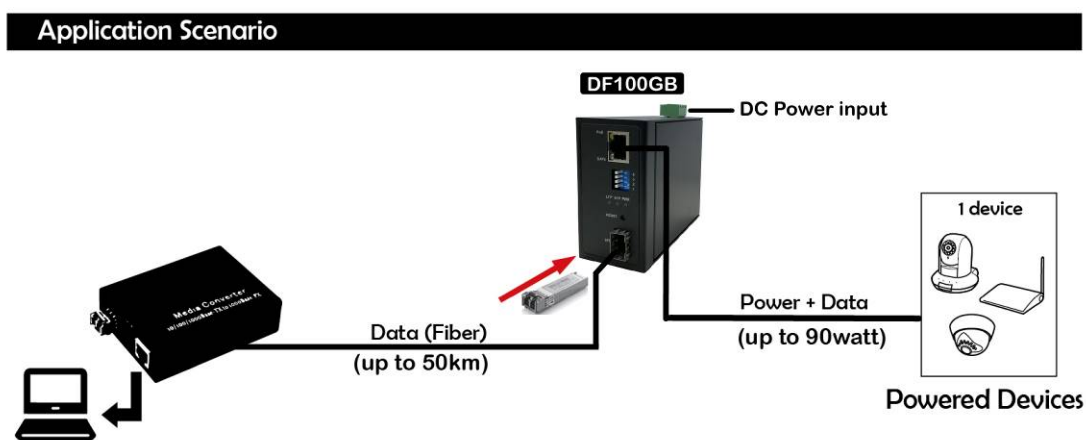

Yoda Communications, Inc. www.yoda.com.tw

2F, No. 3-1, Industry East Road IX, Science Based Industrial Park, HsinChu, Taiwan

Tel:+886-3-563-2323 Fax:+886-3-563-6420